

Binding Your Quilts

Some bind by hand, we bind by Pfaff!

Binding is the last step in finishing your quilt. For finished binding 3/8" wide, cut binding strips 2" wide. This width works perfectly when using the Bi-Level Topstitch Foot w/IDT (#820676096). Depending on personal preference, the strips can be cut on the cross grain. They do not have to be cut on the bias, unless the edge of your quilt is curved. Any curved edge requires bias cut binding. You need to cut enough strips with combined length to go around your quilt with 4" extra.

1. Seam your binding strips end to end. A bias seam will give you less bulk. To sew a bias seam, place the two strips right sides together at a right angle as shown. Stitch from corner, to corner and then trim the excess.

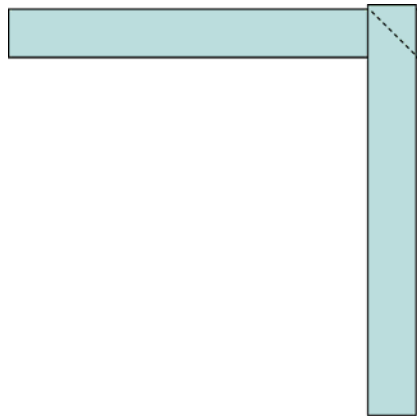

2. Press the seam open.

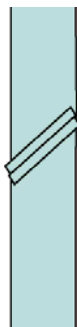

3. Press the binding in half, lengthwise, wrong sides together. This double thick binding will wear better along the quilt edges.

4. Place the raw edges of the binding, even with the raw edge of the quilt. Begin the binding in the center of one of the edges. Select straight

stitch, needle down. Snap on the Bi-Level Topstitching Foot. Engage IDT. Align the binding with the edge of the foot and start sewing two to three inches from the end.

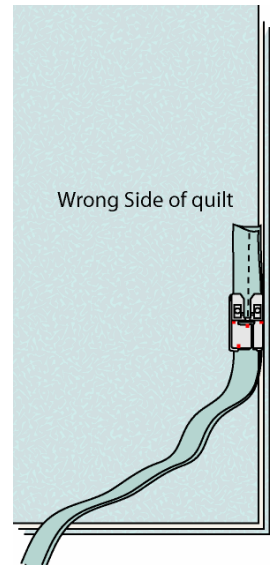

5. Stitch to within 1/2" of the corner and stop with the needle in the fabric.

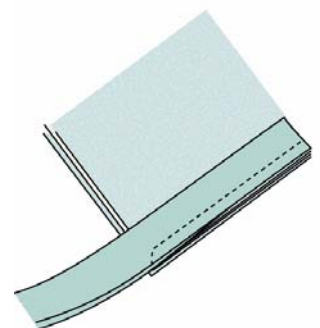
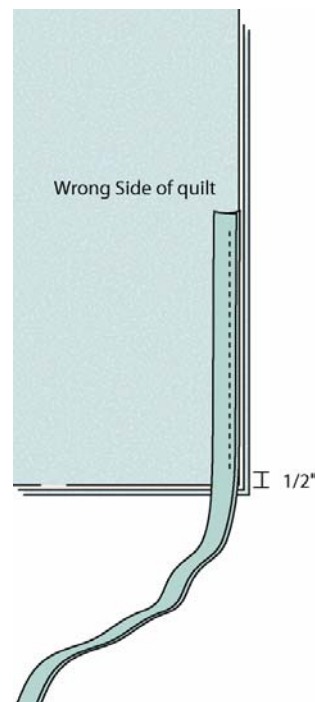

6. Raise the presser foot and pivot the quilt and sew to the corner as shown.

7. Remove the quilt from the machine. Fold the binding straight up at a 90 degree angle as shown.

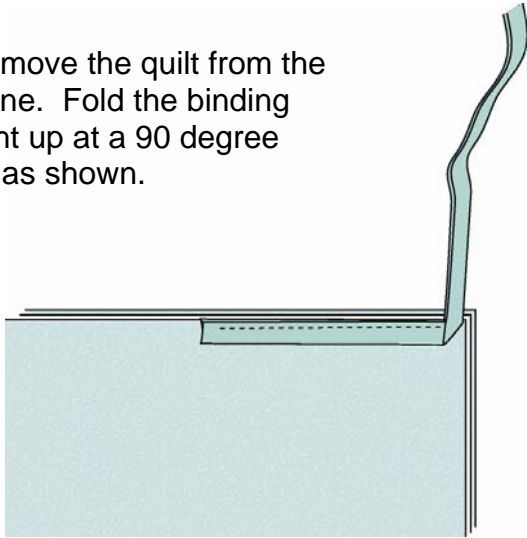

8. Then fold straight down.

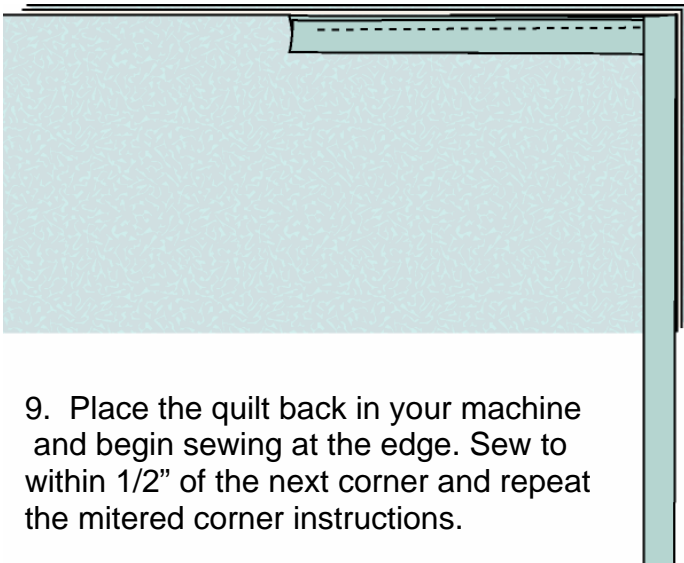

9. Place the quilt back in your machine and begin sewing at the edge. Sew to within 1/2" of the next corner and repeat the mitered corner instructions.

10. To join the binding when you get back to the beginning, stop sewing about 3" before you meet the end of the binding where you started sewing. You should have a few inches of tail on

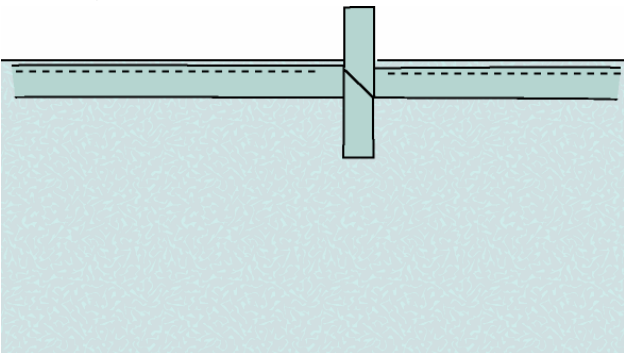

the binding at both the beginning and the end. Fold the binding to meet on the bias as shown, and press to form a crease.

11. Unfold the binding, and carefully pin the creases right sides together. Then mark the sewing lines. Sew the binding ends right sides together along the crease lines. Refold, and stitch the remaining several inches of the binding.

12. Press the binding

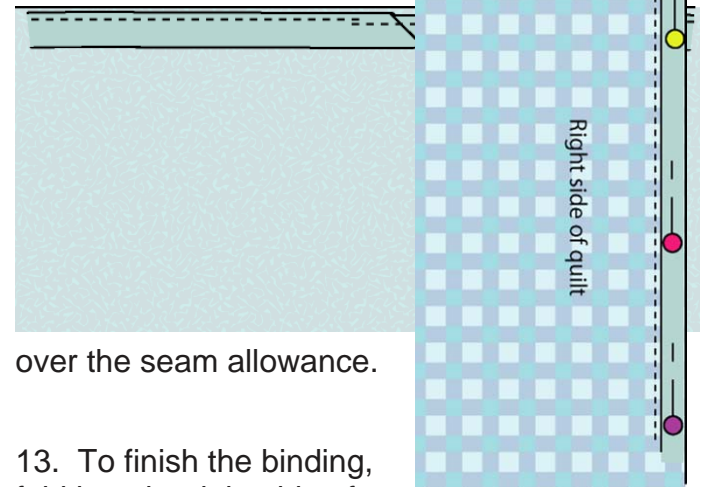

over the seam allowance.

13. To finish the binding, fold it to the right side of the quilt, and press. The fold of the binding should just meet the stitching line.

HINT: Insert 1/4" wide Steam-A-Seam 2 underneath the fold of the binding and fuse it in place with plenty of steam to hold the binding in place while stitching.

Stitch the binding in place with the Pinstitch, stitch #18 or a small zig zag. Align the folded edge of the binding with the red mark on the left front of the machine, as shown.

